

The 25th International Workshop-School High Energy Physics and Quantum Field Theory

Probing dynamics of heavy-ion collisions at NICA with charged hadron correlations

A. Chernyshov, G. Eyyubova, V. Korotkikh, I. Lokhtin, S. Petrushanko, A. Sniguirev, E. Zabrodin

*Skobeltsyn Institute of Nuclear Physics
Lomonosov Moscow State University*



Moscow – 2025

Contents & Outline

- **Charge Balance Function (CBF) as a dynamics susceptible charge correlation**
- **Introducing charge correlations into a statistical model**
- **Charge balance functions at RHIC/NICA energies**
- **Summary**

The fundamental goal of research with relativistic heavy-ion beams is to study the properties of the extreme state of subnuclear matter, quark-gluon plasma (QGP), formed at ultra-high energy densities and temperatures.

- ❖ The highest energies achievable today (LHC collider): a high-temperature state of the quark-gluon medium, close to the “protomatter” in the early Universe.
- ❖ Intermediate energies (NICA collider): dynamics of quark-hadron phase transitions, including the search for “critical point” near their boundary.

These two complementary tasks are among the most pressing in modern high-energy physics.

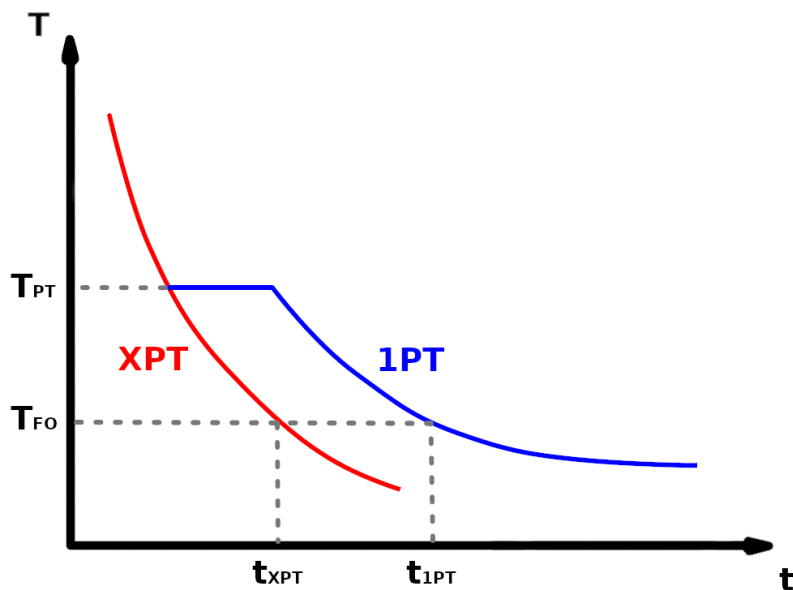
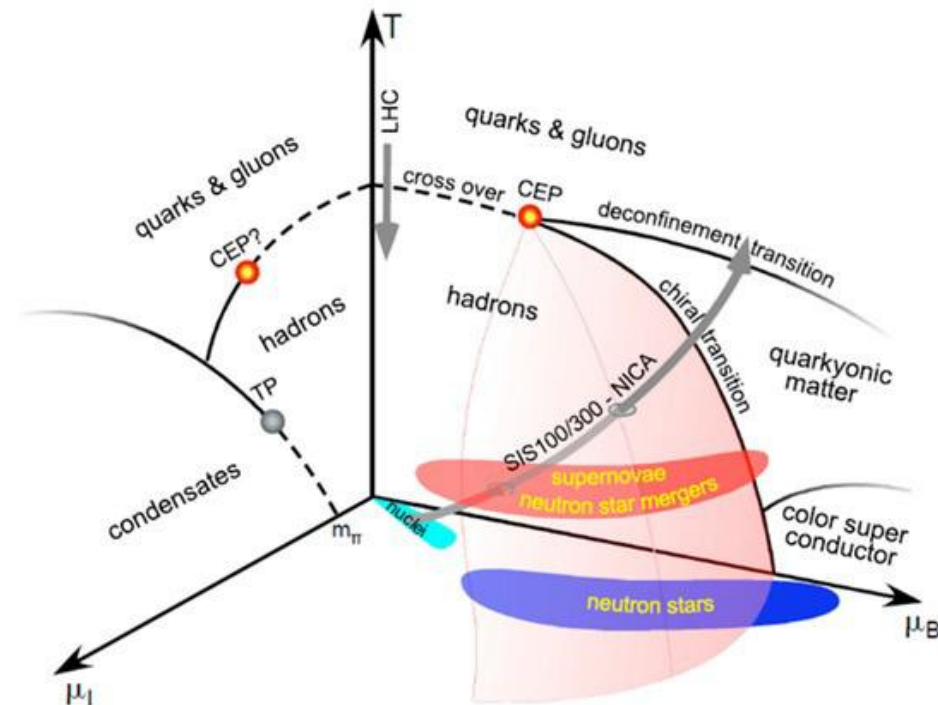

Varying the collision energies of relativistic heavy ions allows us to explore different regions of the QCD phase diagram. At high energies of the RHIC and LHC colliders, the transition from the QGP to the hadron gas is expected to occur via a crossover phase transition (XPT), while at intermediate energies, a first-order phase transition (1PT) and a critical point transition are predicted to occur.

Charge Balance Functions of unlike-sign particles

$$B(\Delta\eta, \Delta\varphi) = \frac{1}{2} \left\{ \frac{\langle N^{+-}(\Delta\eta, \Delta\varphi) \rangle - \langle N^{++}(\Delta\eta, \Delta\varphi) \rangle}{\langle N^+ \rangle} + \frac{\langle N^{-+}(\Delta\eta, \Delta\varphi) \rangle - \langle N^{--}(\Delta\eta, \Delta\varphi) \rangle}{\langle N^- \rangle} \right\},$$

where N^+ is number of pairs of oppositely charged particles whose rapidities η_1 and η_2 satisfy the condition $|\eta_1 - \eta_2| = \Delta\eta$, and similarly, for $\Delta\varphi$. N^+ and N^- are the multiplicities of positively and negatively charged particles respectively. **The balance function (CBF) is the probability density that oppositely charged particles are separated by certain intervals of (pseudo-)rapidity and azimuthal angle. The CBF is characterized by rapidity and azimuthal widths.**

$$\langle \Delta\eta \rangle = \frac{\int B(\Delta\eta) \Delta\eta d\Delta\eta}{\int B(\Delta\eta) d\Delta\eta} \cong \frac{\sum_i B_i \Delta\eta_i}{\sum_i B_i} \quad \langle \Delta\varphi \rangle = \frac{\int B(\Delta\varphi) \Delta\varphi d\Delta\varphi}{\int B(\Delta\varphi) d\Delta\varphi} \cong \frac{\sum_i B_i \Delta\varphi_i}{\sum_i B_i}$$

The CBF is sensitive to the time of electric charge separation during the evolution of the system – **information about spatiotemporal characteristics of the particle emission region, including the presence and type of the quark-hadron phase transition.**

Long-range charge correlations (wide distribution) \longrightarrow early charge separation
 Short-range charge correlations (narrow distribution) \longrightarrow late charge separation

CBFs were measured in heavy-ion experiments at the SPS, RHIC, and LHC accelerators.

Modern theoretical models struggle to describe CBFs \longrightarrow unaccounted correlation mechanisms?

Calculation and correction of Charge Balance Functions

$$\frac{P^{+-}}{P^+} = \frac{P^{+-}(\Delta\eta, \Delta\varphi)}{P^+} \longrightarrow \frac{1}{N^+} \frac{d^2 N^{+-}(\Delta\eta, \Delta\varphi)}{d\Delta\eta d\Delta\varphi}$$

Here N^+ is number of positive hadrons, $d^2 N^{+-}/d\Delta\eta d\Delta\varphi$ is the distribution of positive-negative hadron pairs by relative pseudorapidity and azimuthal angle.

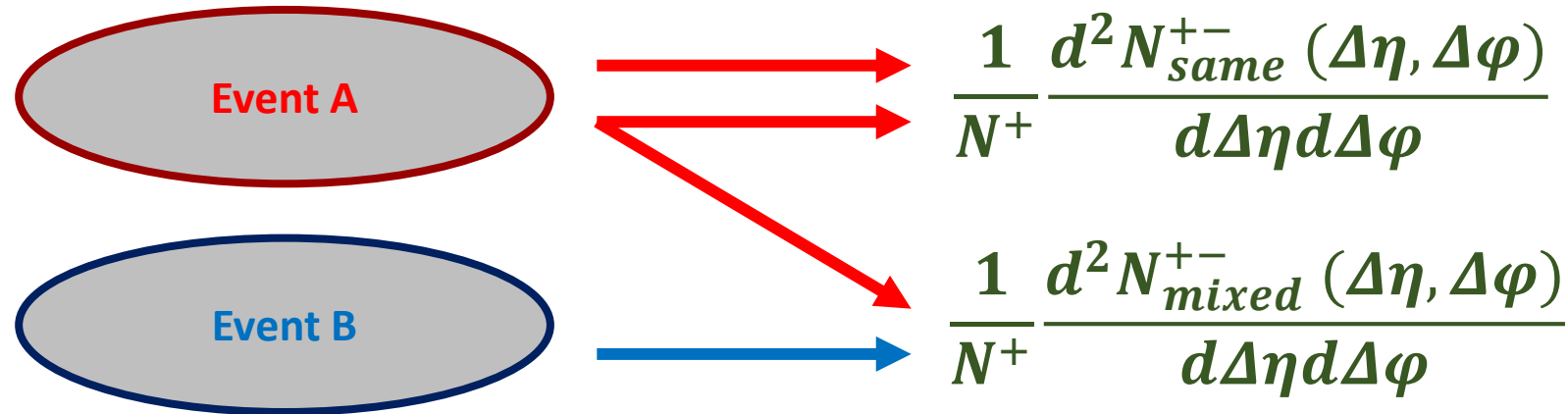

In case of excess positive charge (NICA/RHIC) to suppress distortion, the CBFs should be corrected according to the formula below:

$$\frac{1}{N^+} \frac{d^2 N^{+-}(\Delta\eta, \Delta\varphi)}{d\Delta\eta d\Delta\varphi} = \frac{1}{N^+} \frac{d^2 N_{same}^{+-}(\Delta\eta, \Delta\varphi)}{d\Delta\eta d\Delta\varphi} - \frac{1}{N^+} \frac{d^2 N_{mixed}^{+-}(\Delta\eta, \Delta\varphi)}{d\Delta\eta d\Delta\varphi}$$

Calculation and correction of Charge Balance Functions

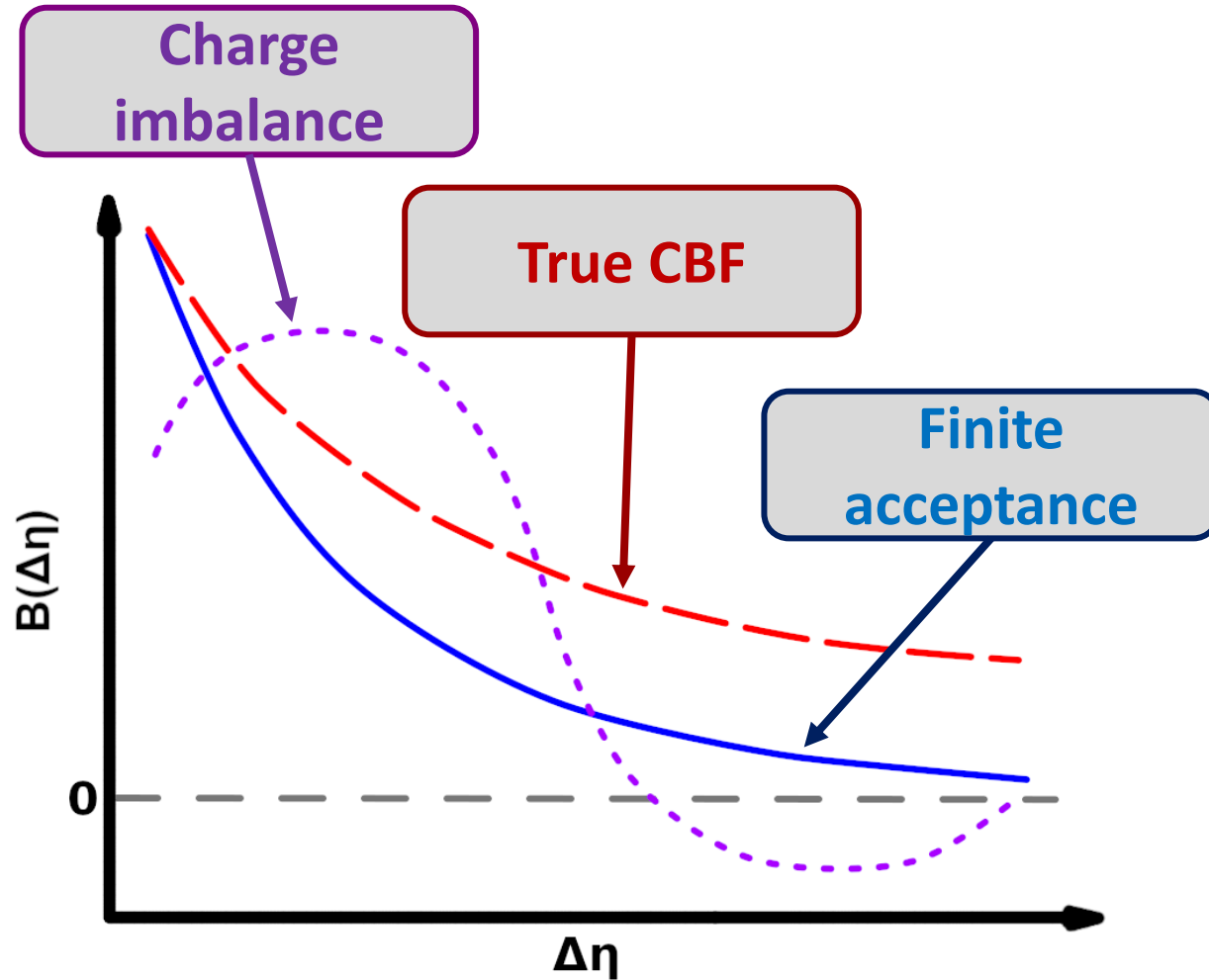

To take into account the influence of the finite angular acceptance of the detector of modeling and experimental analysis, the method described in [STAR Coll., Phys. Rev. C 94 (2) 024909 (2016)] is used, in which the charge imbalance-corrected CBF is multiplied by weighting factors:

$$B(\Delta\eta|\infty) = \frac{B(\Delta\eta|\Delta\eta_{max})}{\left(1 - \frac{\Delta\eta}{\Delta\eta_{max}}\right)}$$

In case of azimuthal hermiticity of the detector, correction of the azimuthal CBF is not required.

HYDJET++ model (HYDroynamics & JETs)

The HYDJET++ model (<http://lav01.sinp.msu.ru/~igor/hydjet++>) is an event generator for studying various characteristics of multiple hadron production in relativistic collisions heavy ions in a wide energy range [I.P.Lokhtin et al., Comp. Phys. Com. 180, 779 (2009)].

The final state of a nuclear reaction in HYDJET++ is a superposition of two independent components:

- ❖ **A thermal hadronic state (soft component), based on the parametrization of the equations of relativistic hydrodynamics;**
- ❖ **A multiparton jet state (hard component) obtained by modifying the characteristics of the hadronic jets of the PYTHIA generator.**

The soft component modeling part of HYDJET++ is written in the object-oriented C++ language and uses a number of libraries from the ROOT software environment (<https://root.cern.ch>). The hard component modeling part is written in FORTRAN. **The presented results were obtained using HYDJET++ version 2.4.**

Introduction of charge correlations into a statistical model

«Towards the centrality dependence description of the charge balance function in the HYDJET++ model»

A. Chernyshov, G. Eyyubova, V. Korotkikh, I. Lokhtin, L. Malinina, S. Petrushanko, A. Snigirev, E. Zabrodin

Chinese Physics C 47 (2023) 084107

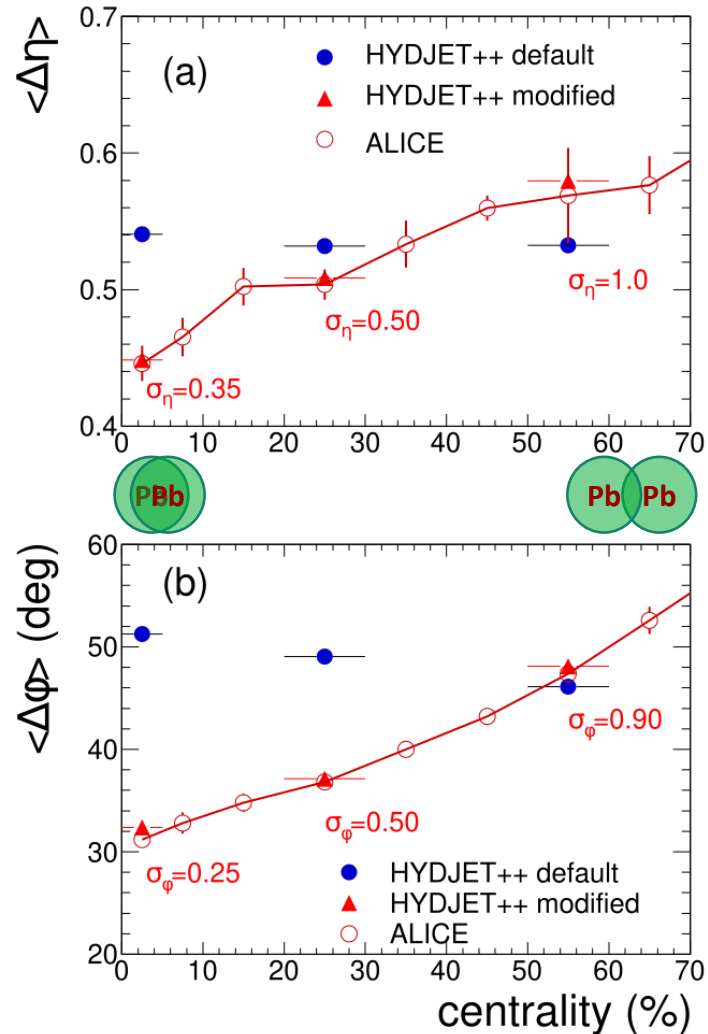

□ A model study of CBFs in Pb+Pb collisions at LHC energies of 2.76 TeV showed that the charge correlations of the final state particles (resonances decay and jets fragmentation) in the HYDJET++ model are insufficient to describe the ALICE data on the dependence of the CBF width on centrality.

□ A modification of statistical (soft) production of primordial charged hadrons in the HYDJET++ model with charge conservation in each event at the freezeout stage is proposed: production of particle-antiparticle pairs with angles (η_1, φ_1) and (η_2, φ_2) distributed according to Gaussian with standard deviations $(\sigma_\eta, \sigma_\varphi)$.

The developed approach made it possible to describe the data on CBF (σ_η and σ_φ increase with the peripherality of collisions).

Accounting for charge imbalance at RHIC/NICA energies in the HYDJET++ model

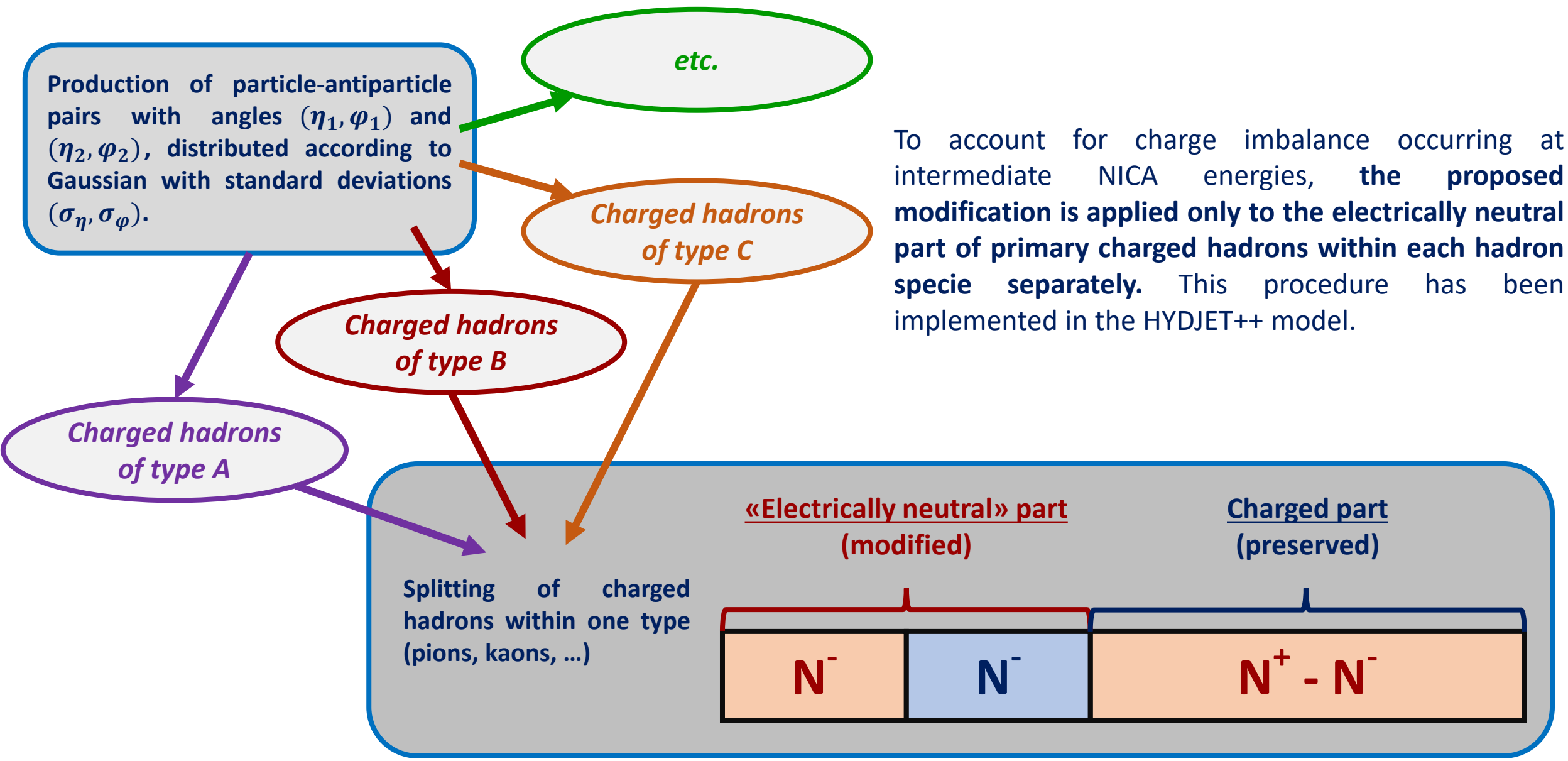

To account for charge imbalance occurring at intermediate NICA energies, the proposed modification is applied only to the electrically neutral part of primary charged hadrons within each hadron specie separately. This procedure has been implemented in the HYDJET++ model.

Tuning the HYDJET++ model for NICA/RHIC energies with STAR data

		π^+/π^-	K^+/K^-	p/\bar{p}
7.7 GeV	RHIC STAR	0.93 ± 0.12	2.70 ± 0.31	141 ± 24
	HYDJET++	0.89	2.70	130
	$\mu_{I,S,B}$ (MeV)	6	100	429
11.5 GeV	RHIC STAR	0.95 ± 0.14	2.03 ± 0.28	29.3 ± 5.3
	HYDJET++	0.93	1.99	28.2
	$\mu_{I,S,B}$ (MeV)	7	72	313

Ratios and multiplicities of oppositely charged hadrons in central Au+Au collisions at RHIC energies and values of chemical potentials (μ_I – isospin, μ_S – strangeness, μ_B – baryon) in the HYDJET++ model. Experimental yields are described fairly well by the model at non-zero chemical potentials.

Balance functions at energies of 7.7 and 11.5 GeV in the HYDJET++ model

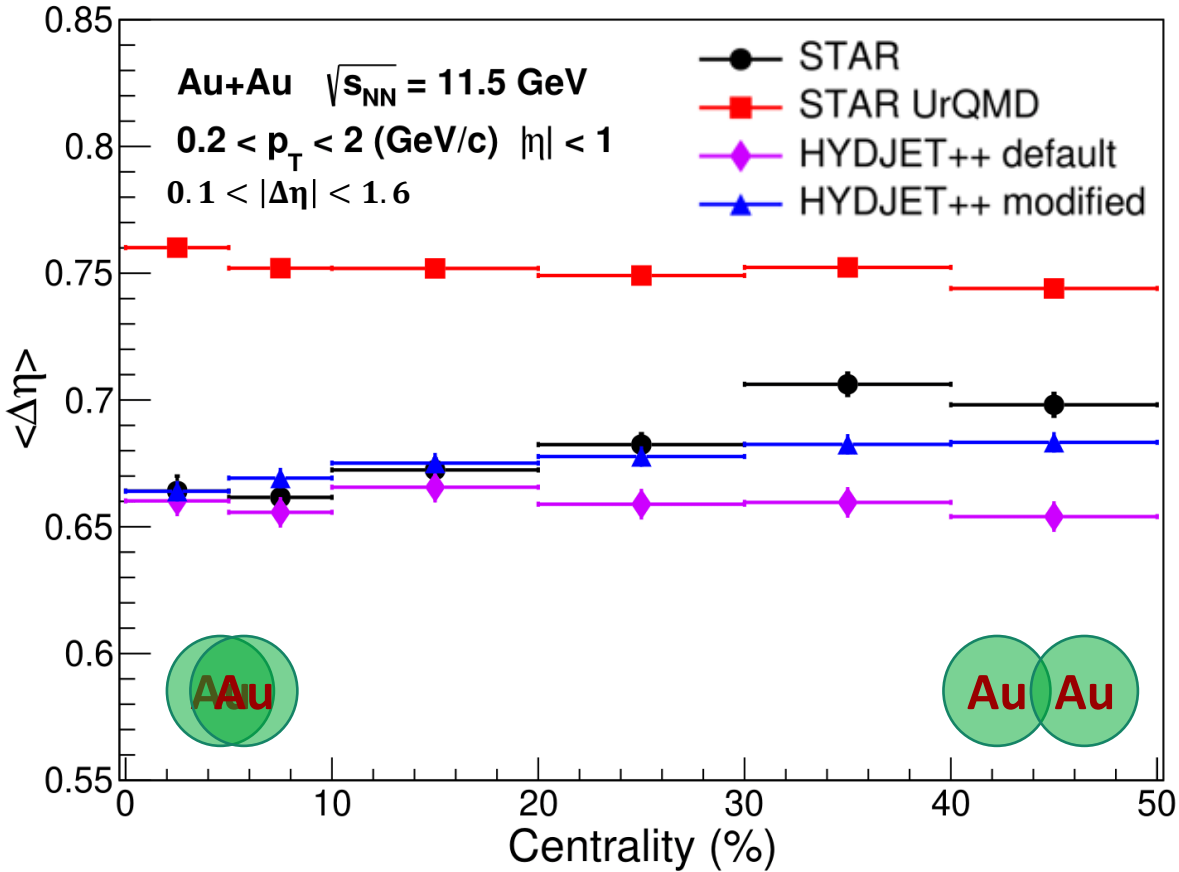
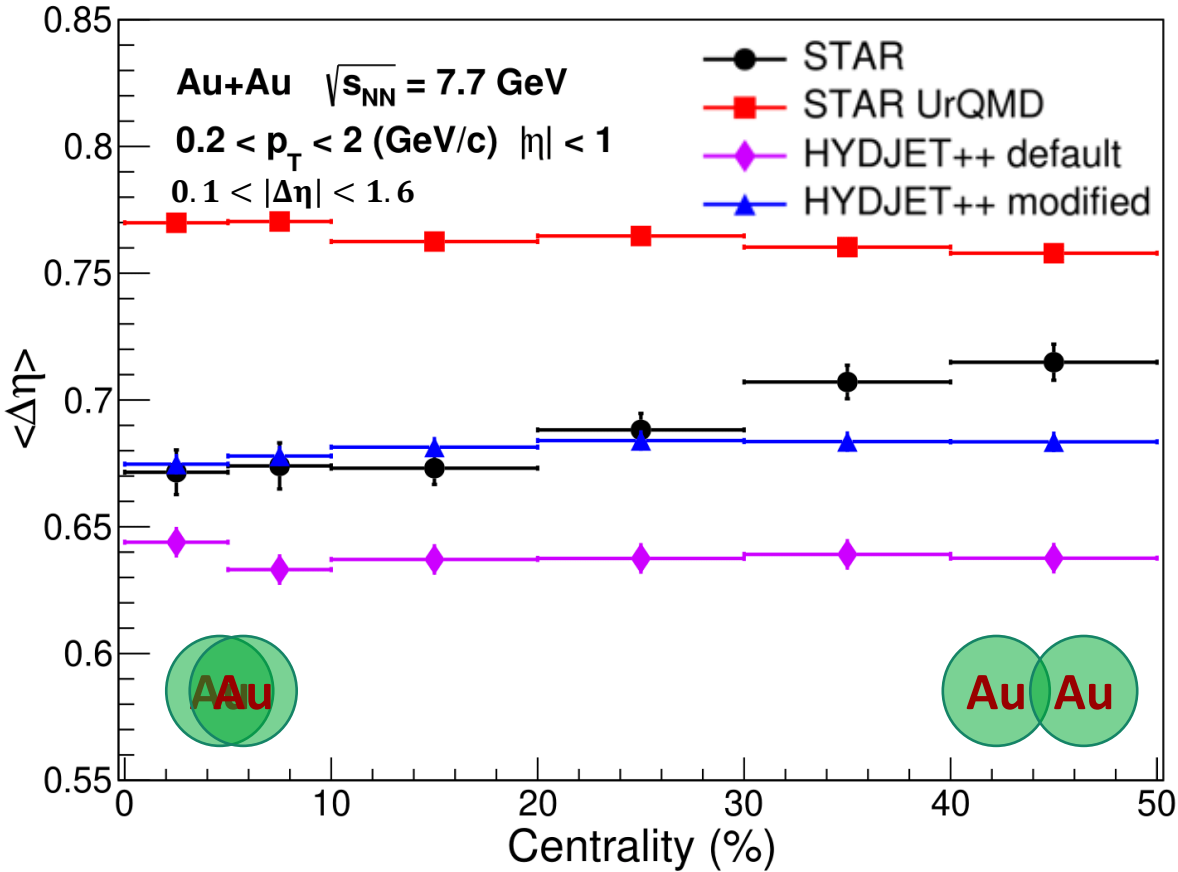

UrQMD and the standard version of HYDJET++ do not reproduce the experimental dependencies of the CBF rapidity widths on centrality. The modification of HYDJET++ allows us to significantly improve the description of the data (it reproduces widths up to 30% of centrality well, but there is some underestimation of the data for more peripheral collisions).

Charge balance function at RHIC/NICA energies in the HYDJET++ model

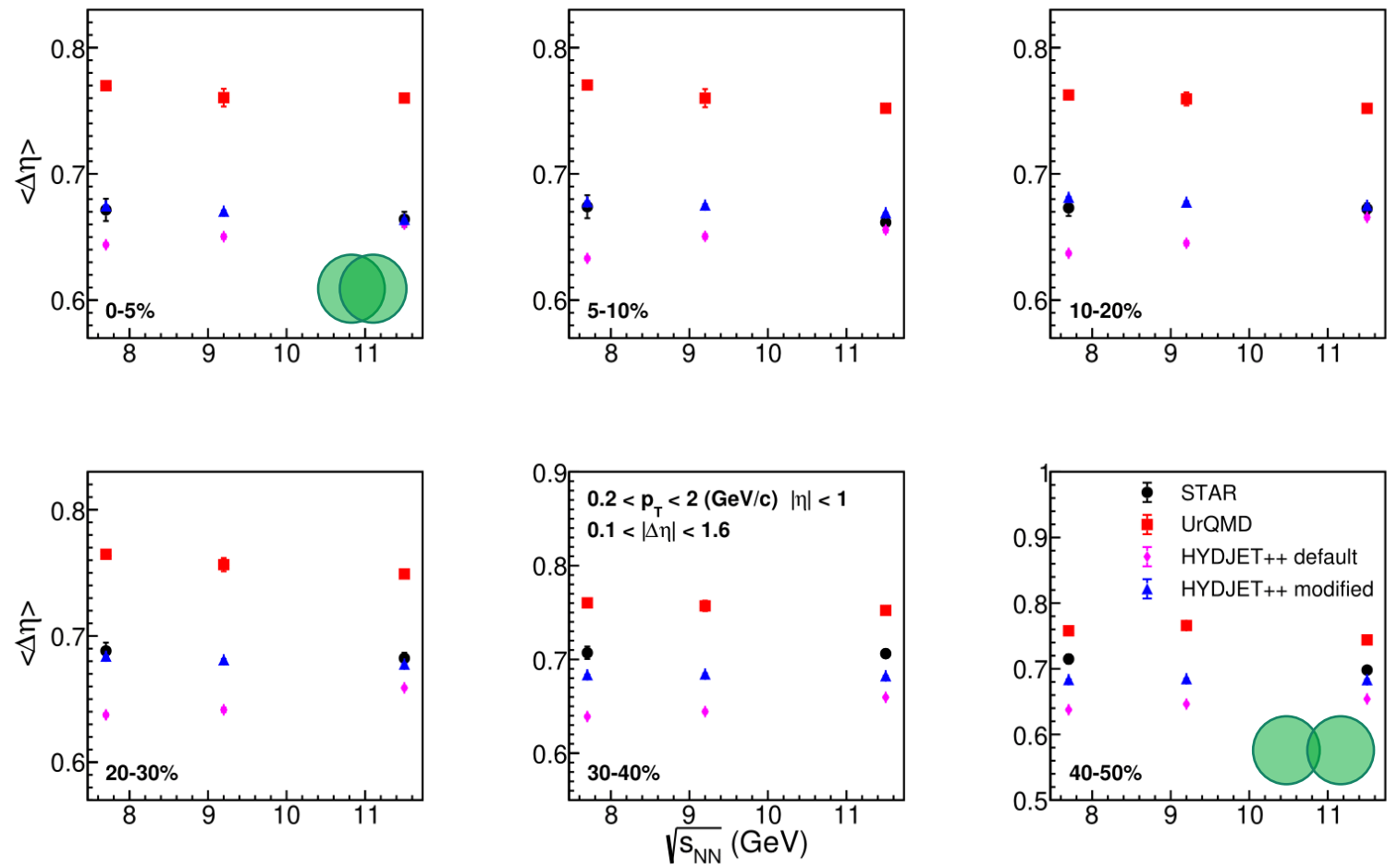

The UrQMD model and the standard HYDJET++ version do not reproduce the experimental data. The modified HYDJET++ reproduces the data in 30% of the most central collisions (there is an underestimation of the data in more peripheral collisions). Additionally, the HYDJET++ predictions for energy of 9.2 GeV in the Bi+Bi collisions (one of the planned NICA configurations) are plotted.

Experimental complex MPD at the NICA accelerator

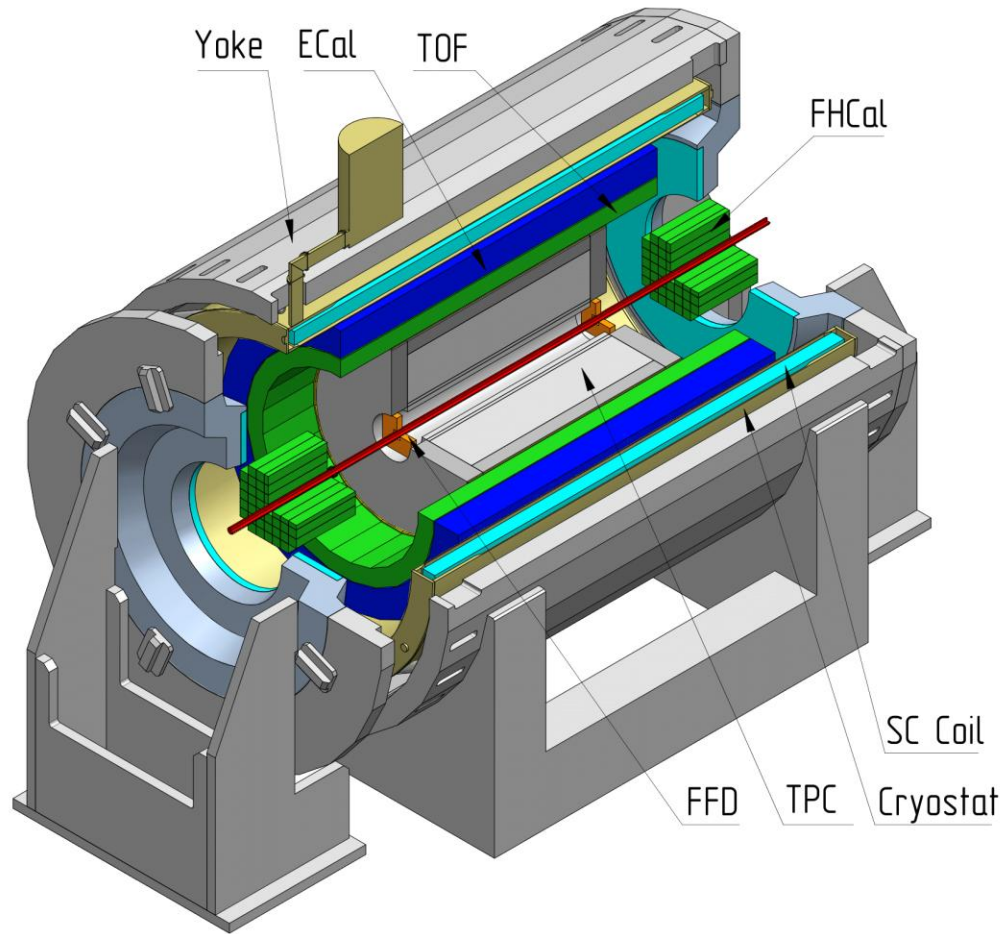

$|\eta| < 1.6$ — Time Projection Chamber, TPC

$|\eta| < 1.4$ — Time-of-Flight sensor, TOF

$|\eta| < 1.4$ — Electromagnetic Calorimeter, ECal

$2.9 < |\eta| < 3.3$ — Fast Forward Detector, FFD

$2.0 < |\eta| < 5.0$ — Forward Hadronic Calorimeter, FHCAL

Current state of CBF reconstruction at MPD/NICA experiment

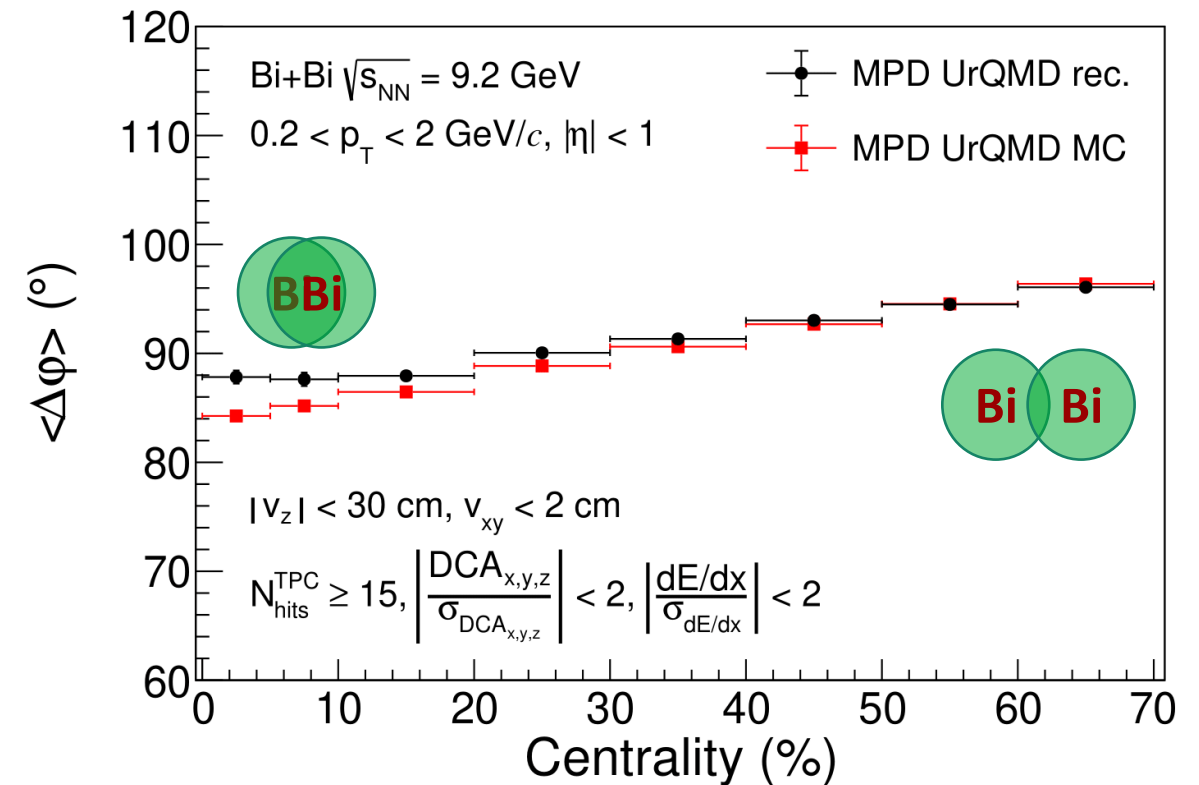
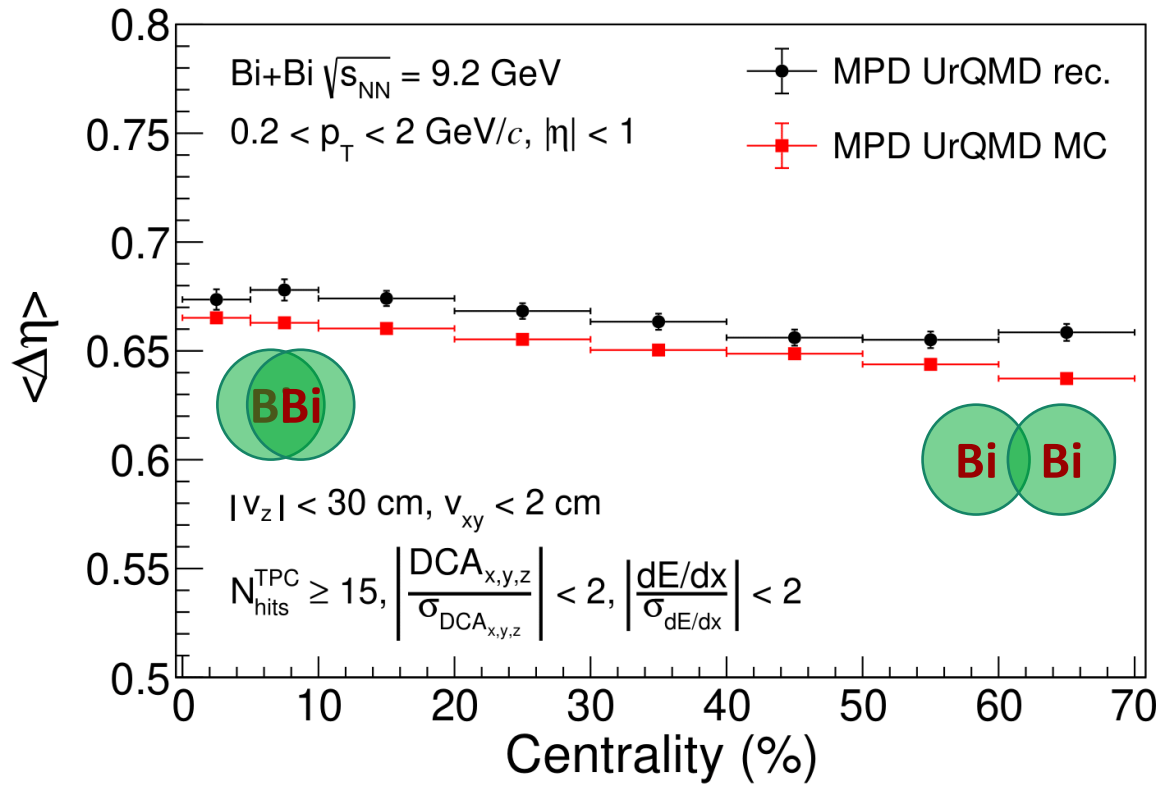

MPD Cross-PWG Meeting, 17 June 2025
<https://indico.jinr.ru/event/5473>

The widths of the charge balance functions reconstructed in the MPD experimental conditions are close to the generator widths in the UrQMD model. Further studies on reconstruction improvement within MpdRoot framework are underway.

Summary

- ✓ The procedure for taking into account charge correlations of primary hadrons for “electrically neutral” systems (LHC) was generalized for the case of systems with charge imbalance (NICA and RHIC). **Introduction of this procedure into the HYDJET++ model simultaneously with taking into account the finite values of isospin, strangeness, and baryon chemical potentials allowed us to reproduce the experimentally observed dependencies of the CBF rapidity widths on the centrality of Au+Au 7.7 and 11.5 GeV collisions.**
- ✓ Software for reconstruction and measurement of the CBFs was developed and introduced into the MpdRoot framework (official MPD Collaboration software package). **Reconstructed widths are fairly close to MC widths in Bi+Bi collisions at 9.2 GeV (one of the foreseeable MPD configurations) in the UrQMD model.** Further improvement of the reconstruction procedure is underway.

The work was supported by the Russian Science Foundation grant 24-22-00011

Thank you for your time!

Additional slides

Parameters of the HYDJET++ model at NICA and LHC energies

Parameter	Value			Units
$\sqrt{s_{NN}}$	7.7	11.5	2760	GeV
A_w	197	197	208	
T^{ch}	155	162	165	MeV
T^{th}	115	115	105	MeV
μ_B	429	313	0	MeV
μ_S	100	72	0	MeV
μ_I	6	7	0	MeV
τ	6.8	7.2	12.2	fm/c
σ_τ	1.5	1.5	3.5	fm/c
R	7.8	8.6	13.45	fm
Y_L^{max}	1.2	1.2	4.5	
U^{max}	0.74	0.74	1.265	

Here $\sqrt{s_{NN}}$ is the energy per pair of nuclei in the center of mass system, A_w is the atomic weight of the nucleus, T^{ch} is the chemical freezeout temperature, T^{th} is the thermal freezeout temperature, μ_B is the baryon chemical potential per unit charge, μ_S is the chemical potential of "strangeness" per unit charge, μ_I is the isospin chemical potential per unit charge, τ is the proper time during thermal freezeout in central collisions, σ_τ is the emission time during thermal freezeout in central collisions, R is the maximum transverse radius during thermal freezeout in central collisions, Y_L^{max} is the maximum rapidity of the longitudinal flow during thermal freezeout, U^{max} is maximum transverse flow rapidity during thermal freezeout in central collisions.

Parameters of the HYDJET++ model at NICA energies

Centrality, %	σ_η	
	7.7 GeV	11.5 GeV
0-5	1.25	1.00
5-10	1.35	1.08
10-20	1.47	1.17
20-30	1.62	1.30
30-40	1.80	1.44
40-50	2.00	1.60

Here σ_η is the variance of the distribution of generated pair-antiparticles in the procedure for taking into account charge correlations.

Tuning the HYDJET++ model for NICA energies

	$v_{s_{NN}} = 7.7 \text{ GeV}$ 0-5% $0.2 < p_T < 2 \text{ (GeV/c)}$ $ y < 0.1$		
	RHIC STAR	Default HYDJET++	Modified HYDJET++
π^+	93.4	90.8	90.5
π^-	100	102	101
K^+	20.8	18.5	18.4
K^-	7.7	6.8	6.8
p	54.9	71.2	71.3
\bar{p}	0.39	0.53	0.55
$\pi+K+p$	277	289	289

	$v_{s_{NN}} = 11.5 \text{ GeV}$ 0-5% $0.2 < p_T < 2 \text{ (GeV/c)}$ $ y < 0.1$		
	RHIC STAR	Default HYDJET++	Modified HYDJET++
π^+	124	118	117
π^-	130	127	126
K^+	25.0	23.4	23.4
K^-	12.3	11.7	11.7
p	44.0	57.5	57.5
\bar{p}	1.5	2.1	2.0
$\pi+K+p$	337	339	338

The model and experimental yields of identified charged hadrons are reproduced quite well by the default and modified versions of the HYDJET++ model.

Tuning HYDJET++ model for NICA energies

$\sqrt{s_{NN}} = 7.7 \text{ GeV}$

$\sqrt{s_{NN}} = 11.5 \text{ GeV}$

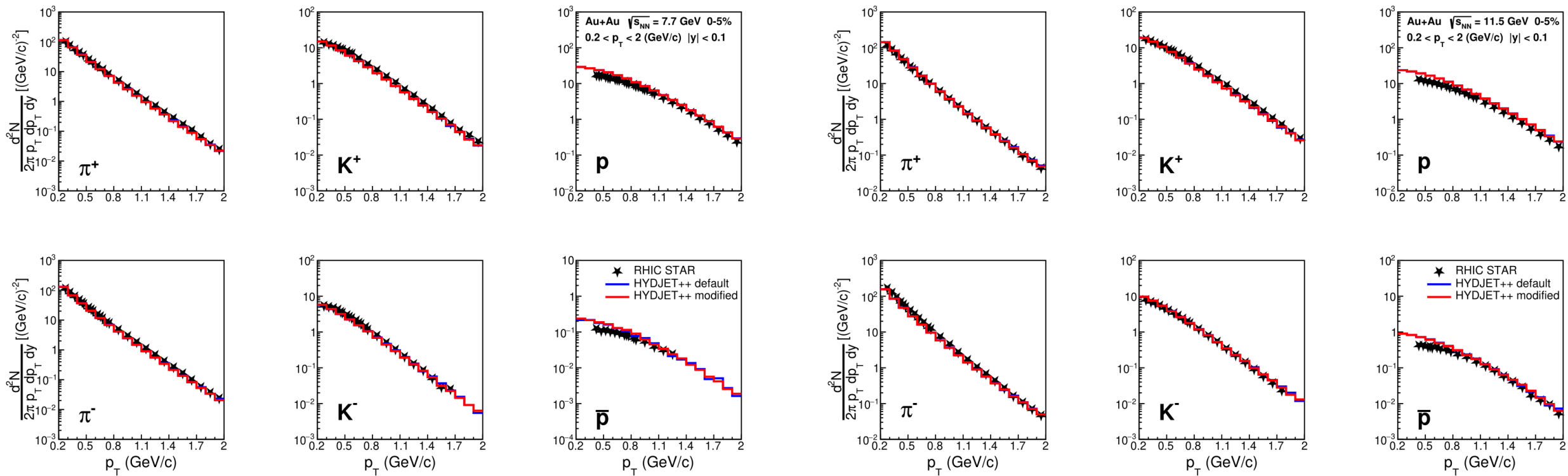

The spectra of identified hadrons in the standard and modified versions of the HYDJET++ model describe the experimental distributions well (somewhat worse for protons, but quite satisfactorily for charged pions and kaons).

Charge balance function of oppositely charged hadrons (RHIC/NICA)

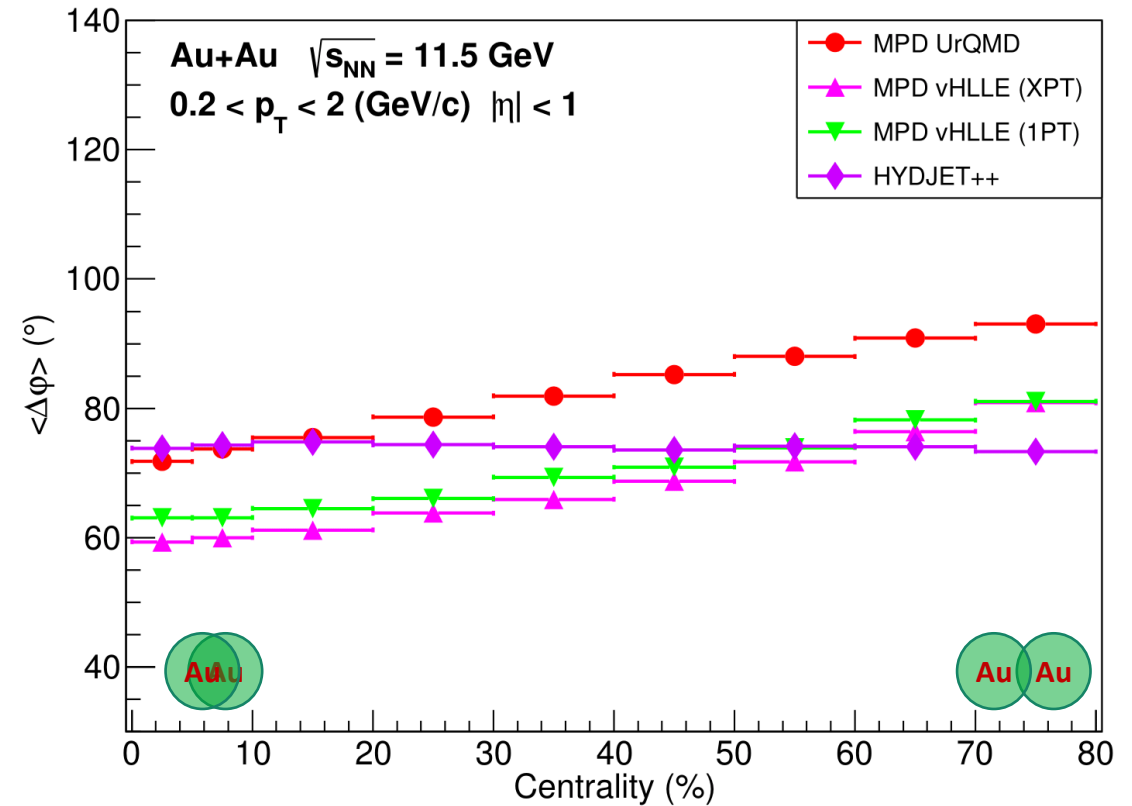
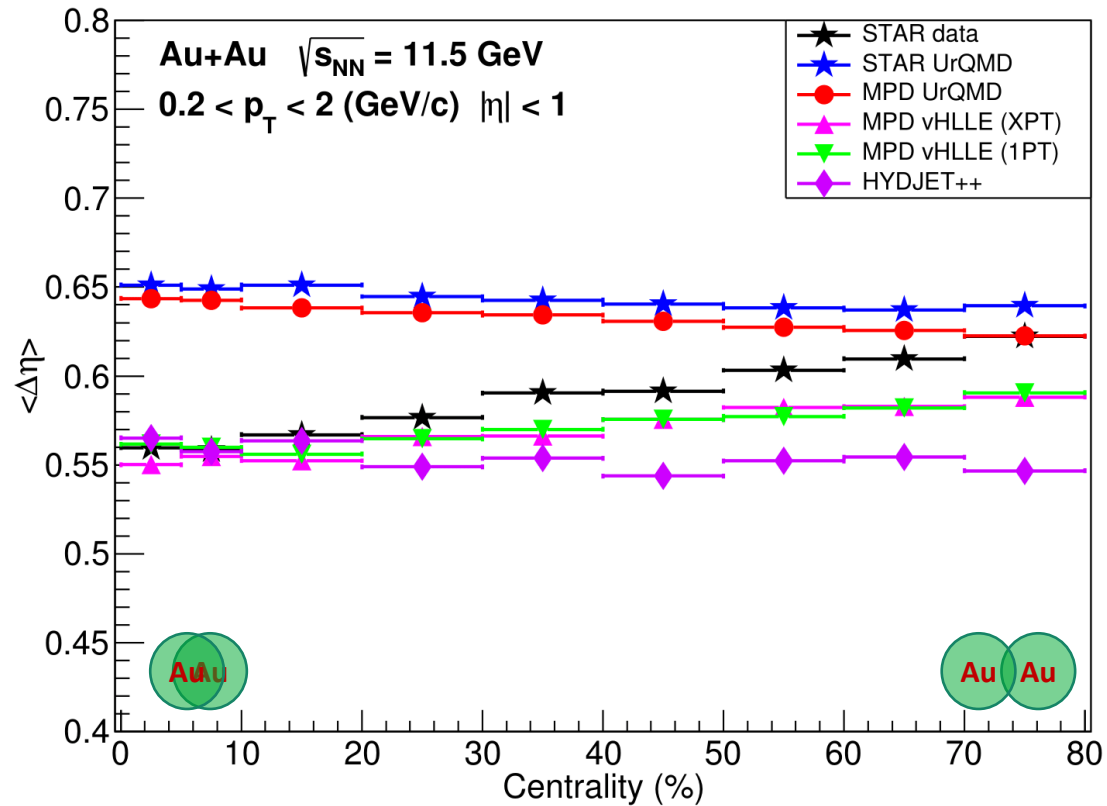

A model study of the CBF with different event generators at energies of 7.7 and 11.5 GeV per nucleon pair was carried out (MPD Cross-PWG <https://indico.jinr.ru/event/3784>):

- ❑ the vHLE and HYDJET++ models reproduce the STAR/RHIC data on the rapidity CBF widths in central collisions, the UrQMD model – in peripheral collisions;
- ❑ none of the models describes dependency of the rapidity CBF width on the centrality of interactions – **unaccounted mechanisms of particle charge correlations in these models?**

The code for constructing the CBF (including corrections for charge imbalance and acceptance) is built into MpdRoot for analyzing simulated events taking into account the detector responses.

Reconstruction of Charge Balance Functions under MPD experimental conditions

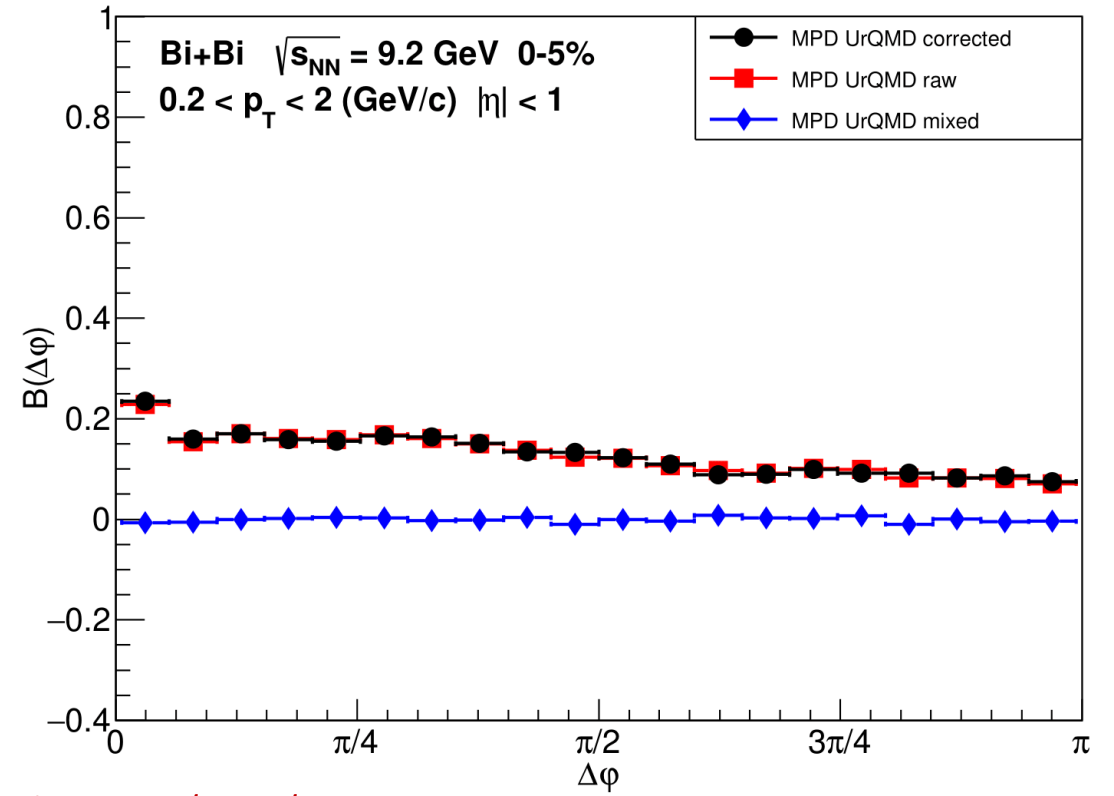
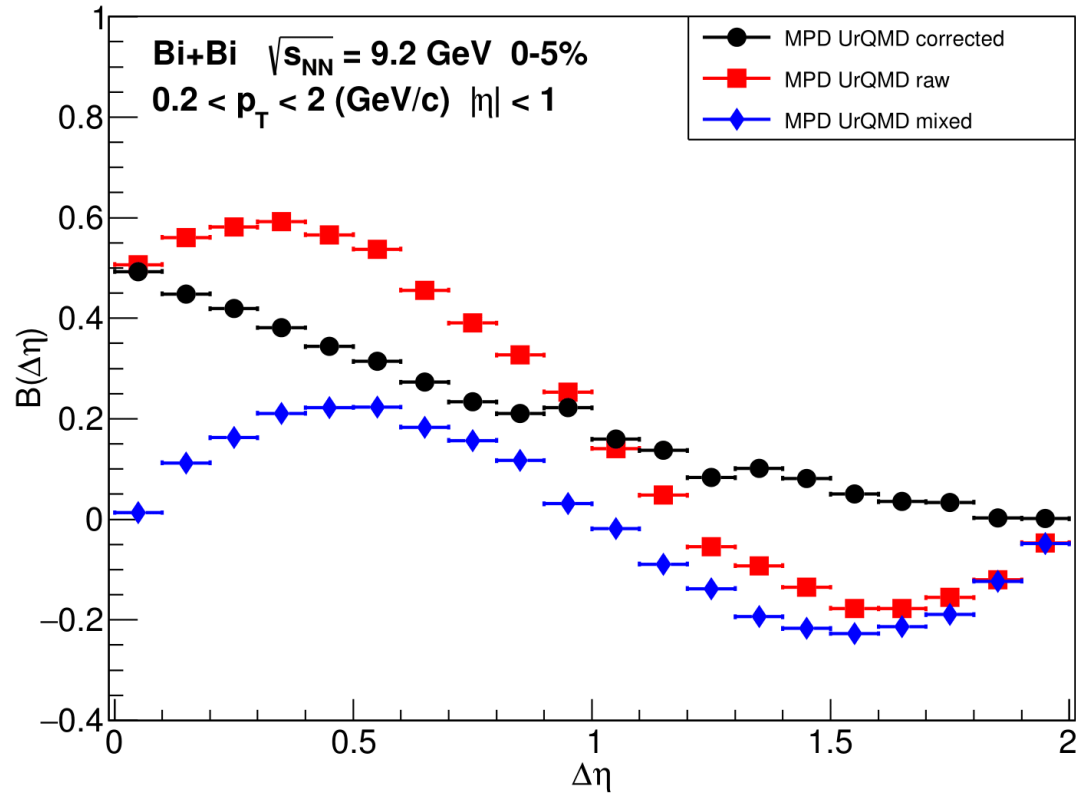

MPD Cross-PWG <https://indico.jinr.ru/event/3784>

Correction procedure for generator CBFs in the UrQMD model in Bi+Bi collisions at NICA $\sqrt{s_{NN}} = 9.2$ GeV. Blue diamonds are the uncorrected CBF, black dots are the corrected function, red squares are the balance function constructed from mixed events.

The effect of the unbalanced positive charge (from protons) at NICA energy distorts the charge balance function. To suppress this effect, the balance function constructed from mixed events is subtracted from the distorted balance function.

Reconstruction of the CBF in the MPD/NICA experiment ($\pi^+\pi^-$, K^+K^-)

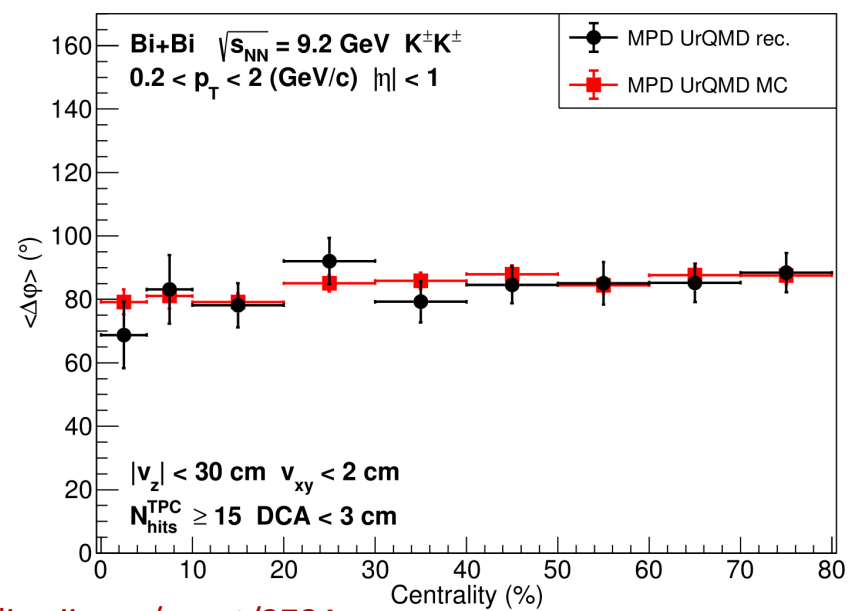
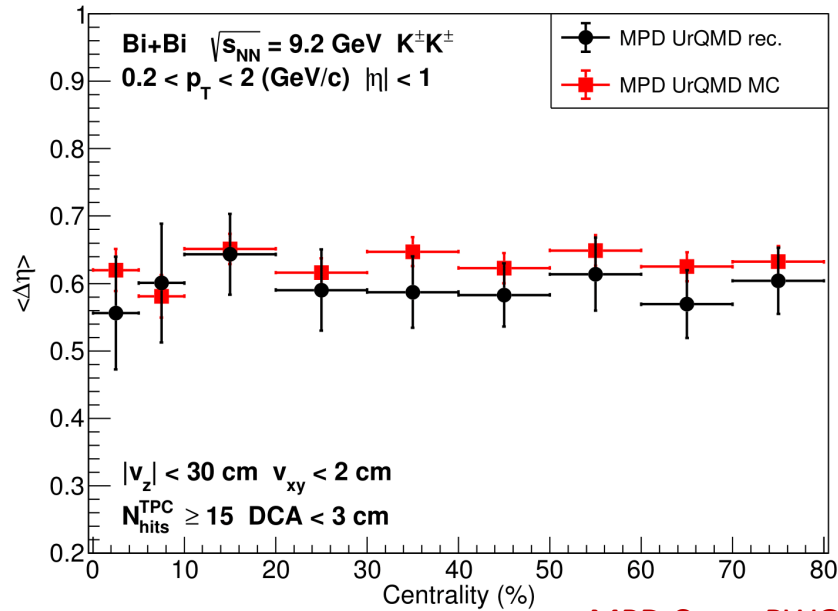
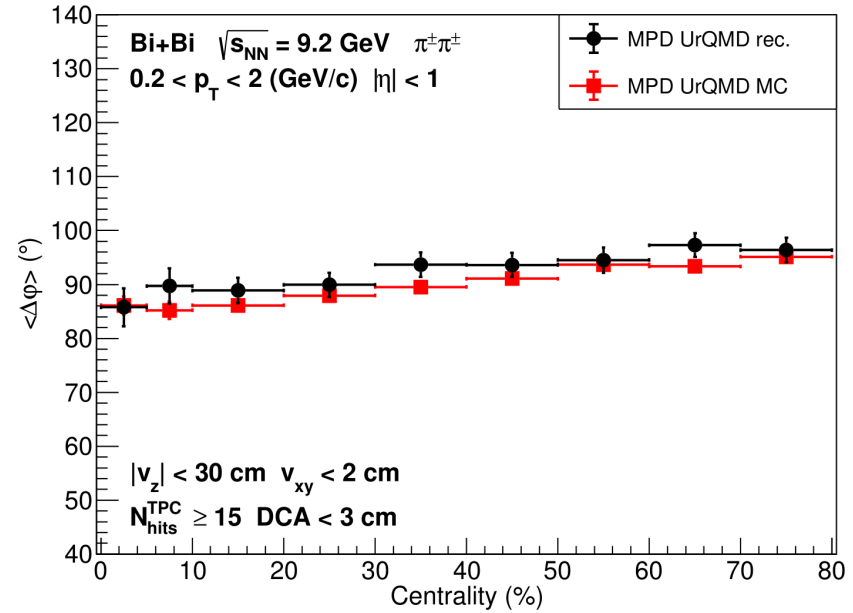
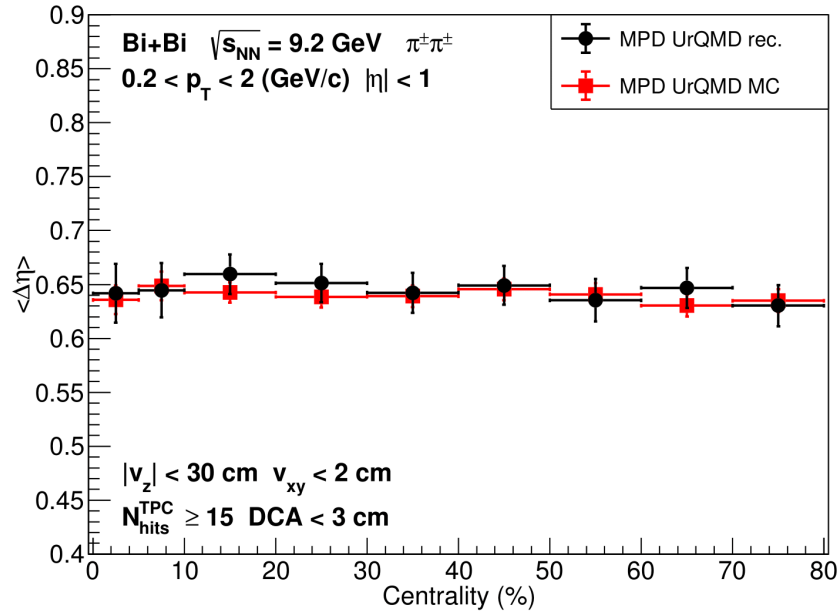

MPD Cross-PWG <https://indico.jinr.ru/event/3784>

Reconstruction of the CBF in the MPD/NICA experiment (π^+K^- , $K^+\pi^-$)

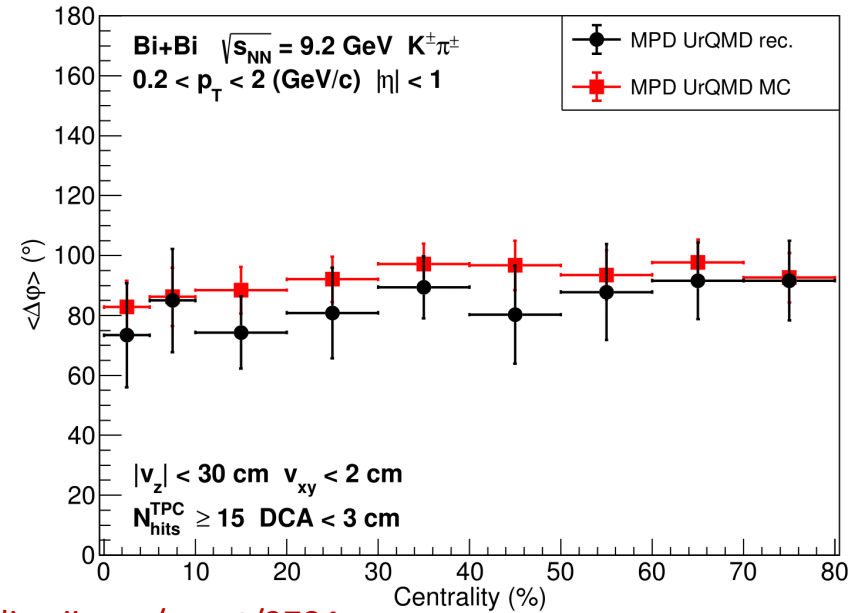
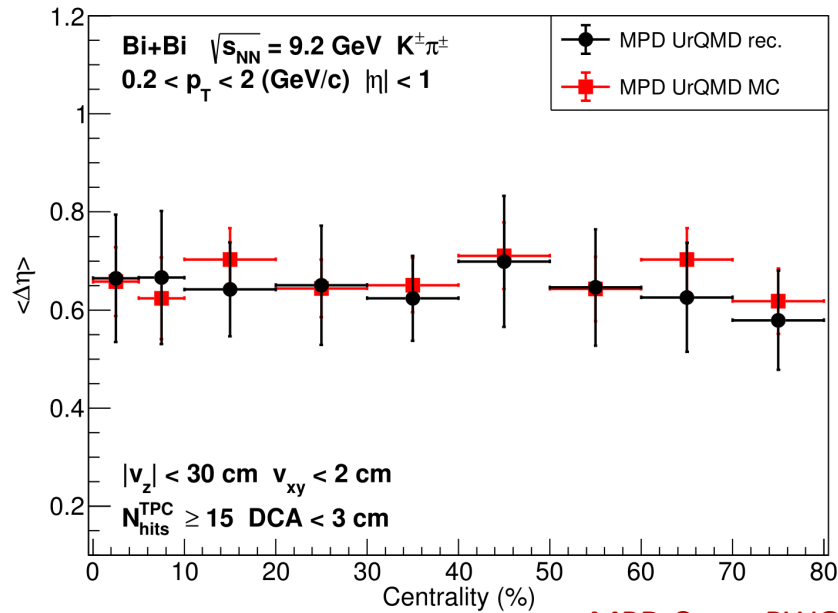
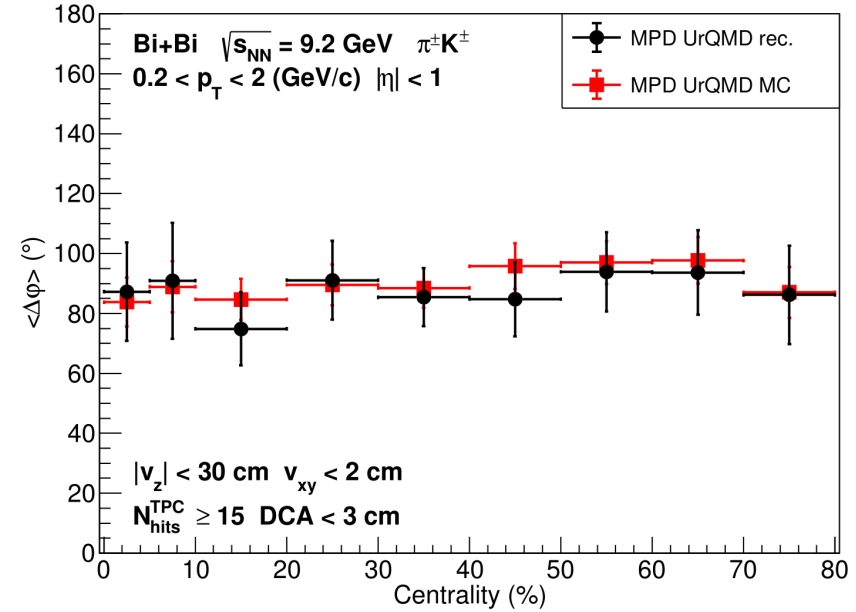
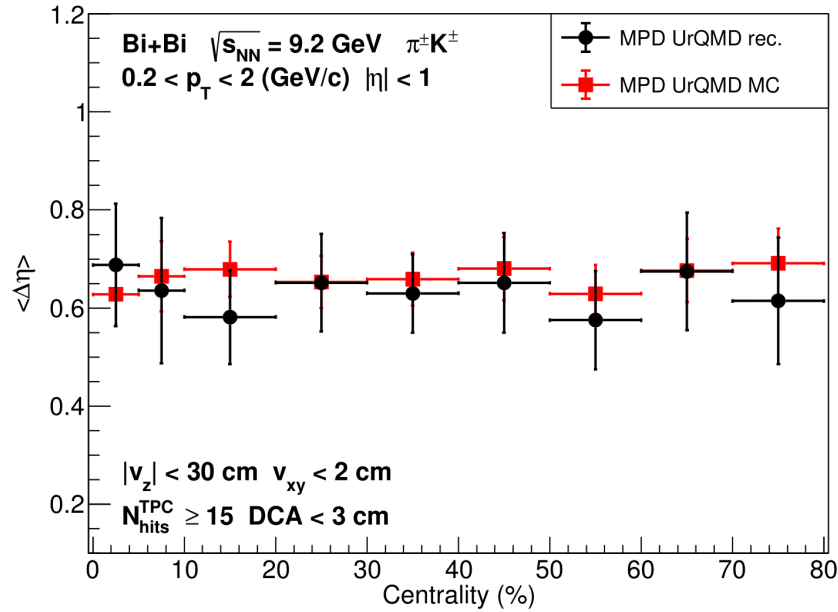

MPD Cross-PWG <https://indico.jinr.ru/event/3784>